



## INSTRUCTION MANUAL

**EMERGENCY POWER SUPPLY**

**VX-2000DS ER**

**VX-2000DS UK**

**VX-2000DS SA**

**POWER SUPPLY FRAME**

**VX-2000PF**

**POWER SUPPLY UNIT**

**VX-200PS ER**

**VX-200PS UK**

**VX-200PS SA**

 1134
TOA Electronics Europe GmbH Suederstrasse 282, 20537 Hamburg, Germany The year in which the marking was affixed is contained in the first two digits of the serial number on the product. 1134-CPD-083
EN 54-4: 1997/A1: 2002 + A2: 2006 Power supply equipment for fire detection and fire alarm systems for buildings VX-2000DS ER/UK, VX-200PS ER/UK

(Does not apply to VX-2000DS SA and VX-200PS SA)

Thank you for purchasing TOA's Emergency Power Supply, Power Supply Frame, and Power Supply Unit.

Please carefully follow the instructions in this manual to ensure long, trouble-free use of your equipment.

**TOA Corporation**

# TABLE OF CONTENTS

<b>1. SAFETY PRECAUTIONS</b> .....	3
<b>2. NOMENCLATURE AND FUNCTIONS</b>	
2.1. VX-2000DS Emergency Power Supply .....	5
2.2. VX-200PS Power Supply Unit .....	7
2.3. VX-2000PF Power Supply Frame .....	8
<b>3. INSTALLATION</b>	
3.1. Assembling the VX-2000PF Power Supply Frame .....	9
3.2. Installing the VX-200PS Power Supply Unit in the VX-2000PF .....	10
3.3. Battery Installation .....	11
3.4. Affixing Declaration of Compliance (EN 54-4 Standard) .....	15
<b>4. CONNECTIONS WHEN USING WITH THE VX-2000 SYSTEM</b>	
4.1. Connections between VX-2000DS and VX-200PS .....	16
4.2. Connecting the VX-2000DS to VX-2000 System .....	17
<b>5. CONNECTIONS WHEN USING WITH THE SX-2000 SYSTEM</b>	
5.1. Connections between VX-2000DS and VX-200PS .....	18
5.2. Connecting the VX-2000DS to SX-2000 System .....	19
5.3. DS Link Terminal Connections .....	21
<b>6. CONNECTIONS WHEN USING WITH THE VM-3000 SYSTEM</b> .....	22
<b>7. CABLE USAGE TABLE</b> .....	26
<b>8. USING THE VX-2000DS EXCLUSIVELY AS A BACKUP POWER SUPPLY</b> .....	27
<b>9. SWITCHING OFF SYSTEM POWER (DC)</b> .....	28
<b>10. BLOCK DIAGRAM</b> .....	29
<b>11. SPECIFICATIONS</b>	
11.1. VX-2000DS Emergency Power Supply .....	30
11.2. VX-200PS Power Supply Unit .....	31
11.3. VX-2000PF Power Supply Frame .....	31

# 1. SAFETY PRECAUTIONS

- Before installation or use, be sure to carefully read all the instructions in this section for correct and safe operation.
- Be sure to follow all the precautionary instructions in this section, which contain important warnings and/or cautions regarding safety.
- After reading, keep this manual handy for future reference.



## **WARNING**

Indicates a potentially hazardous situation which, if mishandled, could result in death or serious personal injury.

### **When Installing the Unit**

- Do not expose the unit to rain or an environment where it may be splashed by water or other liquids, as doing so may result in fire or electric shock.
- Use the unit only with the voltage specified on the unit. Using a voltage higher than that which is specified may result in fire or electric shock.
- (Applicable to VX-2000DS and VX-200PS only)  
Do not cut, kink, otherwise damage nor modify the power supply cord. In addition, avoid using the power cord in close proximity to heaters, and never place heavy objects -- including the unit itself -- on the power cord, as doing so may result in fire or electric shock.
- Since the unit is designed for in-door use, do not install it outdoors. If installed outdoors, the aging of parts causes the unit to fall off, resulting in personal injury. Also, when it gets wet with rain, there is a danger of electric shock.

### **When the Unit is in Use**

- Should the following irregularity be found during use, immediately switch off the main power (or circuit breaker), and contact your nearest TOA dealer. Make no further attempt to operate the unit in this condition as this may cause fire or electric shock.
  - If you detect smoke or a strange smell coming from the unit.
  - If water or any metallic object gets into the unit
  - If the unit falls, or the unit case breaks
  - (Applicable to VX-2000DS and VX-200PS only)  
If the power supply cord is damaged (exposure of the core, disconnection, etc.)
  - If it is malfunctioning (no tone sounds.)
- To prevent a fire or electric shock, never open the unit case nor modify the unit. Refer all servicing to qualified service personnel.
- Do not place cups, bowls, or other containers of liquid or metallic objects on top of the unit. If they accidentally spill into the unit, this may cause a fire or electric shock.
- (Applicable to VX-2000DS and VX-200PS only)  
Do not insert nor drop metallic objects or flammable materials in the ventilation slots of the unit's cover as this may result in fire or electric shock.
- (Applicable to VX-2000DS and VX-200PS only)  
Do not touch a power supply plug during thunder and lightning, as this may result in electric shock.
- (Applicable to VX-200PS only)  
When replacing the fuse, be sure to use the supplied one (3.15 A). Using any other fuse than supplied may cause fire or electric shock.



## CAUTION

Indicates a potentially hazardous situation which, if mishandled, could result in moderate or minor personal injury, and/or property damage.

### When Installing the Unit

- (Applicable to VX-2000DS and VX-200PS only)  
Never plug in nor remove the power supply plug with wet hands, as doing so may cause electric shock.
- (Applicable to VX-2000DS and VX-200PS only)  
When unplugging the power supply cord, be sure to grasp the power supply plug; never pull on the cord itself. Operating the unit with a damaged power supply cord may cause a fire or electric shock.
- (Applicable to VX-2000DS and VX-200PS only)  
Do not block the ventilation slots in the unit's cover. Doing so may cause heat to build up inside the unit and result in fire.
- Avoid installing the unit in humid or dusty locations, in locations exposed to the direct sunlight, near the heaters, or in locations generating sooty smoke or steam as doing otherwise may result in fire or electric shock.
- System units (except remote microphones) are designed exclusively to be mounted in an equipment rack. Be sure to observe the following instructions when rack-mounting the unit. Failure to do so may cause a fire or personal injury.
  - Install the equipment rack on a stable, hard floor. Fix it with anchor bolts or take other arrangements to prevent it from falling down.
  - When connecting the power cord of the DC power supply panel for the units to an AC outlet, ensure that the total load current never exceeds the AC outlet's allowable current capacity.
  - The supplied rack-mounting screws can be used for the TOA equipment rack only. Do not use them for other racks.
- (Applicable to VX-2000DS only)  
Note correct polarity (positive and negative orientation) when connecting the power supply cord. Reversed polarity connections will cause damage to the system.

### When the Unit is in Use

- Use the specified power supply unit for the system. Note that the use of other power supply unit may cause a fire.
- (Applicable to VX-2000DS only)  
Make sure to observe the following handling precautions so that a fire or personal injury does not result from leakage or explosion of the battery.
  - Do not short, disassemble, heat nor put the battery into a fire.
  - Avoid using both new and old batteries together.
  - Never charge batteries of the type which are not rechargeable.
  - Do not solder a battery directly.
  - Be sure to use the specified type of batteries.
  - Note correct polarity (positive and negative orientation) when connecting a battery to the unit.
  - Avoid locations exposed to the direct sunlight, high temperature and high humidity when storing batteries.
- (Applicable to VX-200PS only)  
Contact your TOA dealer as to the cleaning. If dust is allowed to accumulate in the unit over a long period of time, a fire or damage to the unit may result.

## 2. NOMENCLATURE AND FUNCTIONS

### 2.1. VX-2000DS Emergency Power Supply

- Up to 3 (6 ch) VX-200PS Power Supply units can be connected per VX-2000DS to supply backup DC power to individual components.
- Automatically switches to the backup power supply when the DC power supply from the VX-200PS is interrupted.
- Detects charging circuitry or battery failures, and transmits failure signals to the DS LINK of the TOA Voice Evacuation Systems (VX-2000, SX-2000, and VM-3000).
- Keeps a 2 x 12 V sealed lead-acid battery charged while maintaining temperature compensation for the charging voltage.
- Automatically disconnects the battery if its voltage reaches a discharge final level.

[Front]

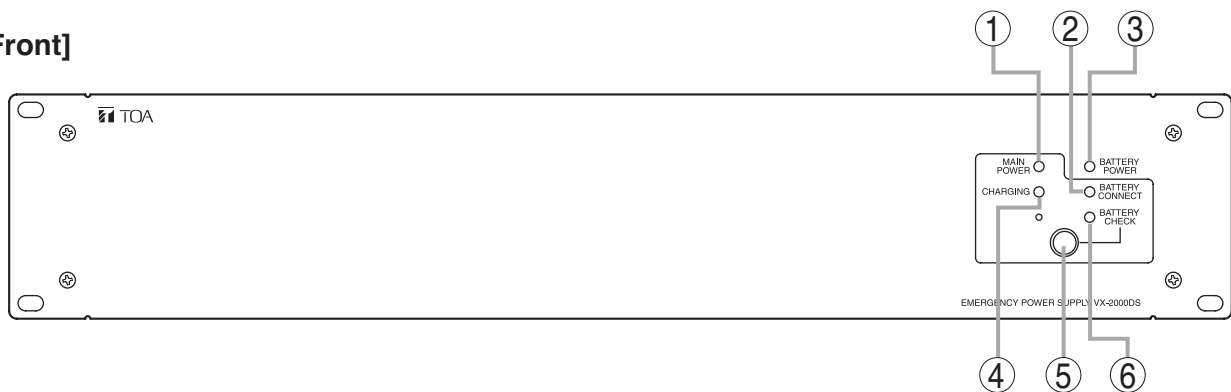

[Rear]

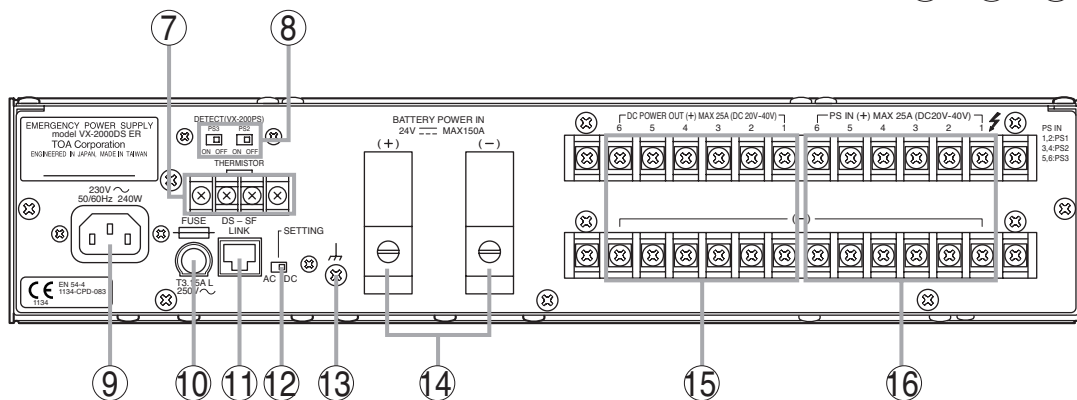

Note: This figure represents the VX-2000DS ER.

[Top]

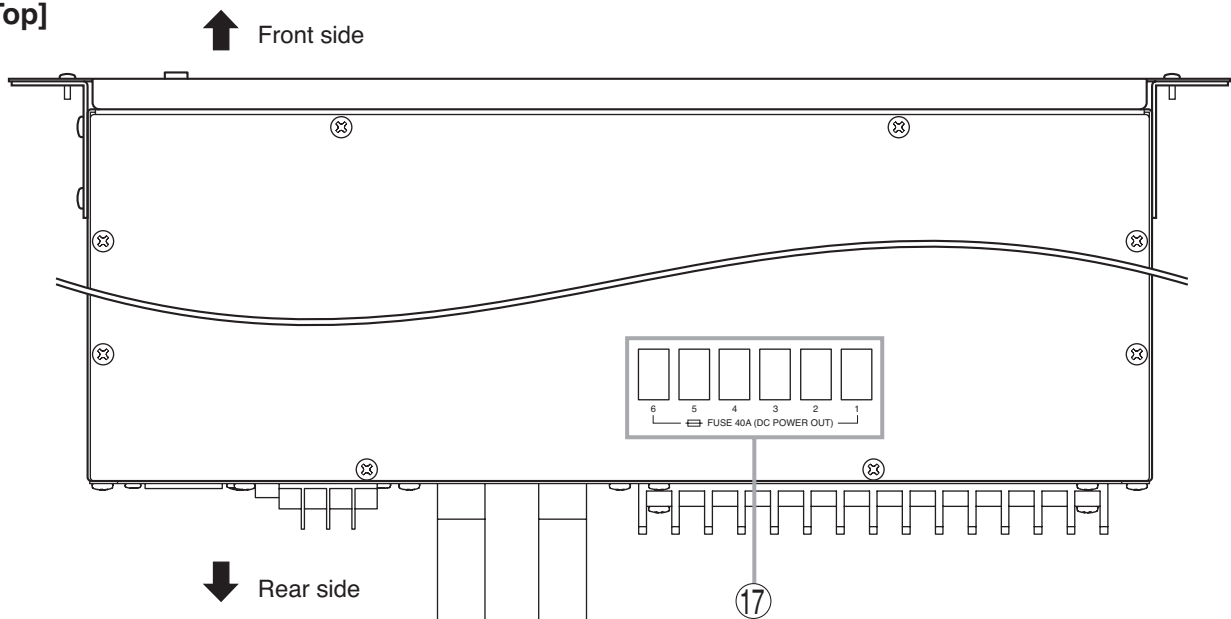

### 1. Power indicator [MAIN POWER]

Lights green when both DC power from the VX-200PS and AC power are supplied.

### 2. Battery connect indicator [BATTERY CONNECT]

Lights green when the battery is connected.

### 3. Battery indicator [BATTERY POWER]

Indicates the state of battery usage. Lights red when the DC power supply is interrupted and switched over to the backup power supply.

### 4. Charging indicator [CHARGING]

Indicates battery charging status. Flashes green while charging, and continuously lights green after charging completion.

### 5. Battery check button

Used to check internal resistance state of the backup battery.

Pressing the button permits measuring of the internal resistance value. The Battery check indicator goes off if the measurement exceeds the specified value.

In automatic mode, the unit performs battery check every 3 and a half hours.

When the DS-SF LINK is connected to the VX-2000 system, SX-2000 system, or VM-3000 system, the resistance measurement is activated by the equipment, not by the unit itself.

#### Note

Battery check cannot function for 1 minute after it has been activated once. In this case, wait a few minutes, then reactivate it.

### 6. Battery check indicator [BATTERY CHECK]

In the AC operated system, the internal resistance value of the battery is measured automatically or manually to check whether the battery is faulty. The Battery check indicator indicates the result.

- Before measurement:
  - Flashes green at 2-second intervals.
- During measurement:
  - Flashes green at 1-second intervals.
- Normal: Lights green.
- Abnormal: Remains unlit.

In the battery-operated system, the battery voltage is constantly monitored and its level is indicated by the indicator as shown below without pressing the Battery check button.

- Lights green: 25 V or more
- Flashes green: 20 – 25 V
- OFF: 20 V or less

### 7. Thermistor connection terminal [THERMISTOR]

Detects the ambient temperature of the backup battery, and performs temperature compensation for the charging voltage. For the installation instructions, refer to p. 14.

### 8. PS detect switches

Always connect a power supply to the terminals 1 + 2 of the DC INPUT. When connecting a power supply to the terminals 3 + 4 of the DC INPUT, set the PS2 switch to ON. When connecting a power supply to the terminals 5 + 6 of the DC INPUT, set the PS3 switch to ON.

### 9. AC inlet

Using the supplied power cord, connect this AC line receptacle to a power source of 230 V AC (ER/UK), 220 – 230 V AC (SA), 50/60 Hz.

### 10. Fuse holder

Requires an AC fuse.  
Type: 250 V, T3.15 A L

### 11. Control connector [DS-SF LINK]

This RJ45 connector connects to DS-SF LINK connector of the VX-2000 system, SX-2000 system, or VM-3000 system.

### 12. Setting switch [SETTING]

Select the DC position (factory set) when using the unit in the VX-2000 system, SX-2000 system, or VM-3000 system.

Select the AC position when using the unit as a backup power supply in an AC-operated system. Refer to p. 27 for the switch setting in the VM-2000 series system or other systems.

### 13. Ground terminal

### 14. Battery connection terminal [BATTERY POWER IN]

Connects to the backup battery.  
Recommended battery: Panasonic LC-X1265PG/APG sealed lead-acid battery

### 15. DC output terminal [DC POWER OUT]

Supplies the DC power to the DC-operated devices.

### 16. DC input terminal [PS IN]

Connects to the DC output terminal of the VX-200PS Power Supply unit or VM-3000 series (Voice Alarm System Amplifier or VM Extension Amplifier).

Be sure to connect the first VX-200PS unit or VM-3000 amplifier to the terminals 1 and 2, the second unit or amplifier to the terminals 3 and 4, and the third unit or amplifier to the terminals 5 and 6.

### 17. Fuse

Provided in each DC output.  
Capacity: Blade-Type Fuse 40 A

**[Fault indication]**

If any of the Power indicator [MAIN POWER], Battery connect indicator [BATTERY CONNECT], Charging indicator [CHARGING], or Battery check indicator [BATTERY CHECK] on the front panel remains unlit, the unit is judged failed. In such cases, remove the cause of the failure, and restore the unit to normal operation.

**Note**

Even if any of these indicators flashes, this does not indicate malfunction.

**2.2. VX-200PS Power Supply Unit**

**Note**

The VX-200PS Power Supply unit is designed for exclusive use with the VX-2000 system, SX-2000 system, and VM-3000 system.

Up to 3 VX-200PS Power Supply units can be mounted in the V-2000PF Power Supply Frame. The VX-200PS unit has 2 DC output channels, and up to 3 units (6 ch) can be connected to one VX-2000DS Emergency Power Supply. Use the VX-200PS in the number suited to the required total system power.

**[Rear]**

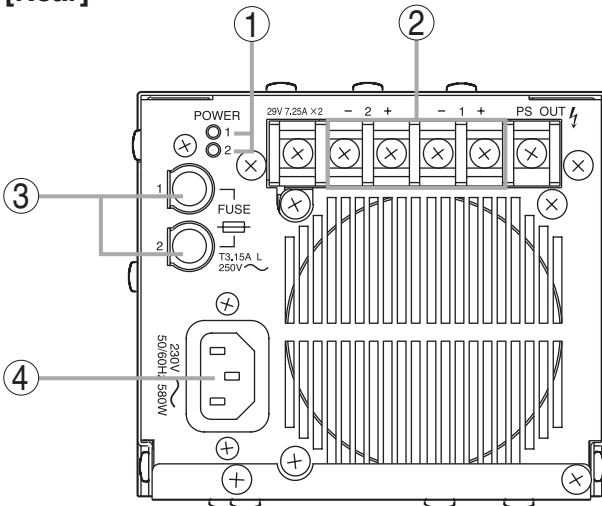

**1. Power indicator [POWER]**

These indicators (one for each channel) light green when DC power is output.

**2. DC output terminal 1, 2 [PS OUT]**

Connects to the PS IN terminals of the VX-2000DS Emergency Power Supply.

**3. AC fuse 1, 2**

Type: 250 V, T3.15 A L

**4. AC inlet**

Using the supplied power cord, connect this AC line receptacle to a power source of 230 V AC (ER/UK), 220 – 230 V AC (SA), 50/60 Hz.

### 2.3. VX-2000PF Power Supply Frame

The VX-2000PF permits the VX-200PS Power Supply to be mounted in an equipment rack. Up to 3 VX-200PS units can be installed in the VX-2000PF. Refer to p. 10 for the VX-200PS mounting procedure.

#### [VX-2000PF Components]

This unit is comprised of the following components. For the component assembly, refer to p. 9.

- 1. Front panel ..... 1
- 2. Side panel ..... 2
- 3. Chassis (VX-200PS guide rails pre-mounted) .....1
- 4. Fixing bracket\* .....1

\* The Fixing bracket is not supplied with the previous VX-2000PF.  
(Refer to p. 9, "Installation Precautions.")

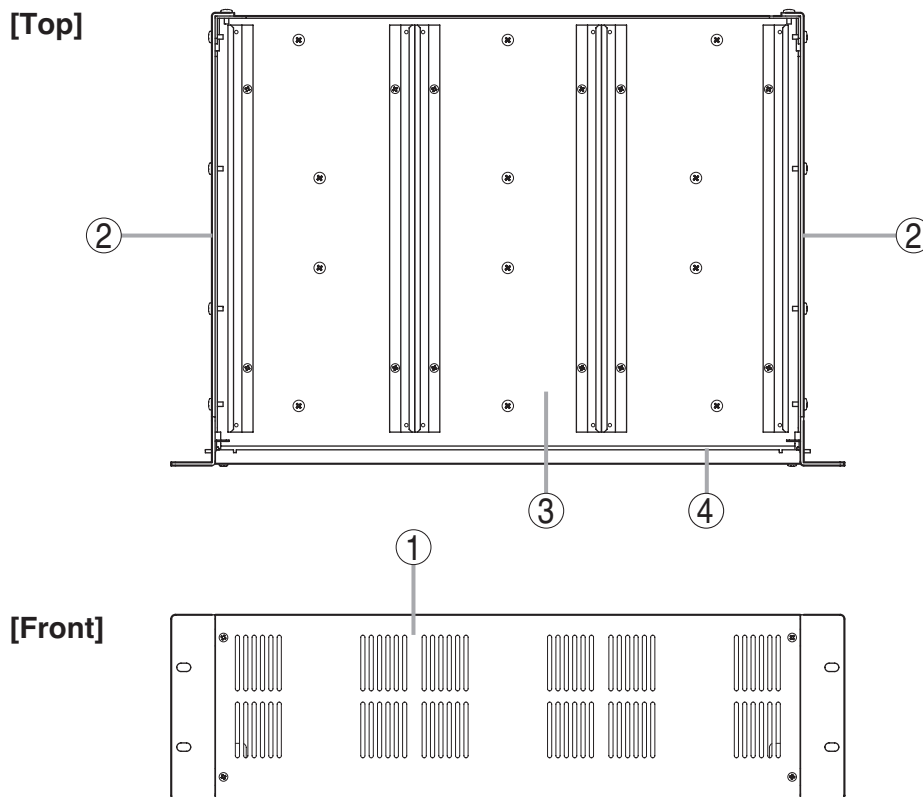



### 3. INSTALLATION

#### 3.1. Assembling the VX-2000PF Power Supply Frame

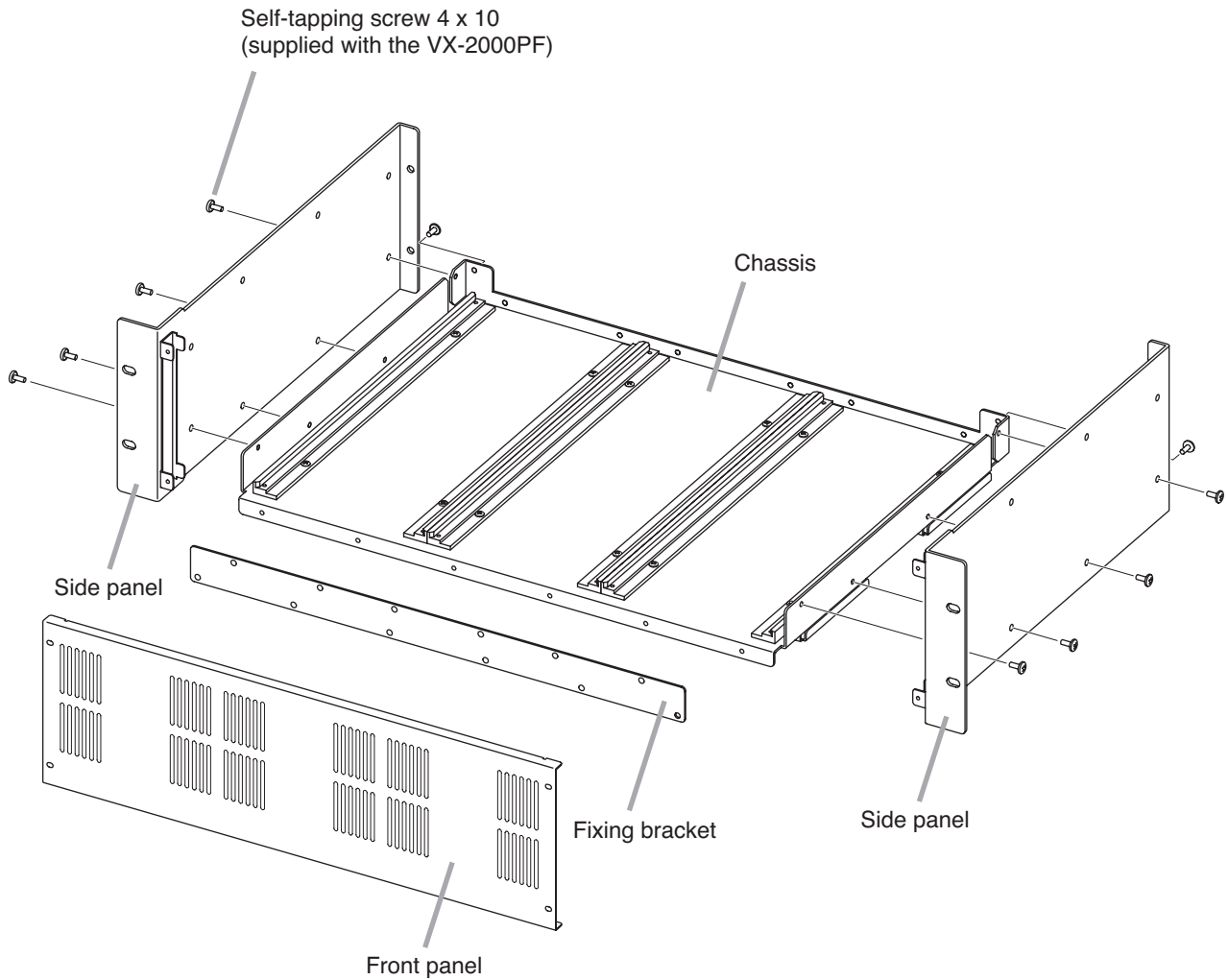

**Note:** Mount the front panel and fixing bracket after installing the VX-200PS units on the chassis.

#### [Installation Precautions]

The VX-2000PF and VX-200PS units are slightly different in specifications between the previous and current production lots.

The previous unit differs from the product explained in this manual in the following points.

Previous VX-2000PF: A Fixing bracket is not supplied.

Previous VX-200PS: A spacer is placed between the front panel and screw. (See the figure below.)

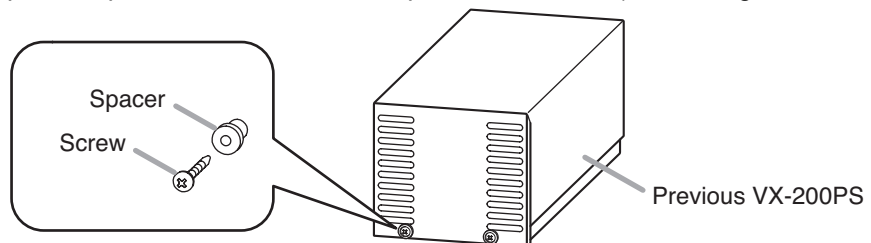

The mounting method for the combination of the current unit and previous unit differs from the steps shown on the next page.

- When mounting the previous VX-200PS in the current VX-2000PF;  
Use only the removed screws without using the spacers removed from the VX-200PS's front panel in **Step 3**.
- When mounting the VX-200PS (previous or current unit) in the previous VX-2000PF;  
There is no need to secure the VX-200PS units using the screws in **Steps 2**, and **3**.

### 3.2. Installing the VX-200PS Power Supply Unit in the VX-2000PF

To be compliant with EN 54-4, install the VX-2000DS and VX-2000PF in the CR cabinet rack series CR-15, CR-22, CR-27, CR-35, CR-40, and CR-44.

**Step 1.** Mount the VX-2000PF in an equipment rack.

**Step 2.** Mount the VX-200PS in the VX-2000PF.

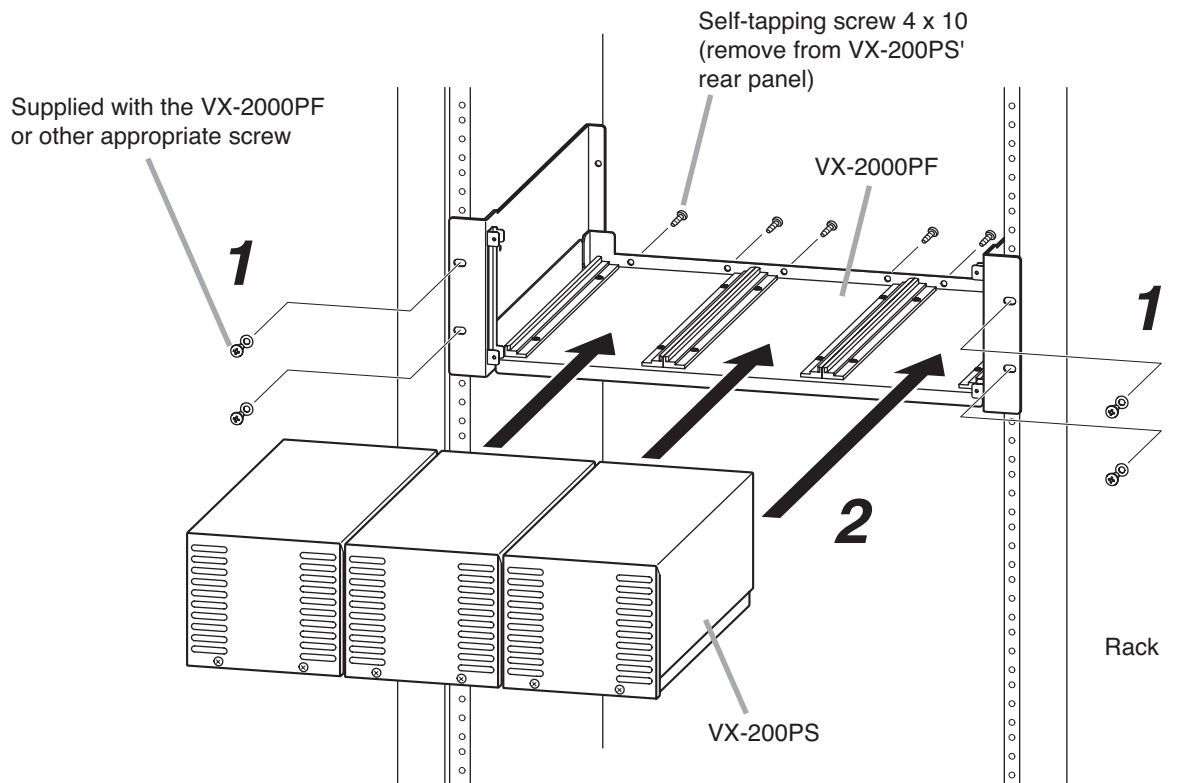

**Step 3.** Fit the VX-2000PF's fixing bracket and front panel in place.

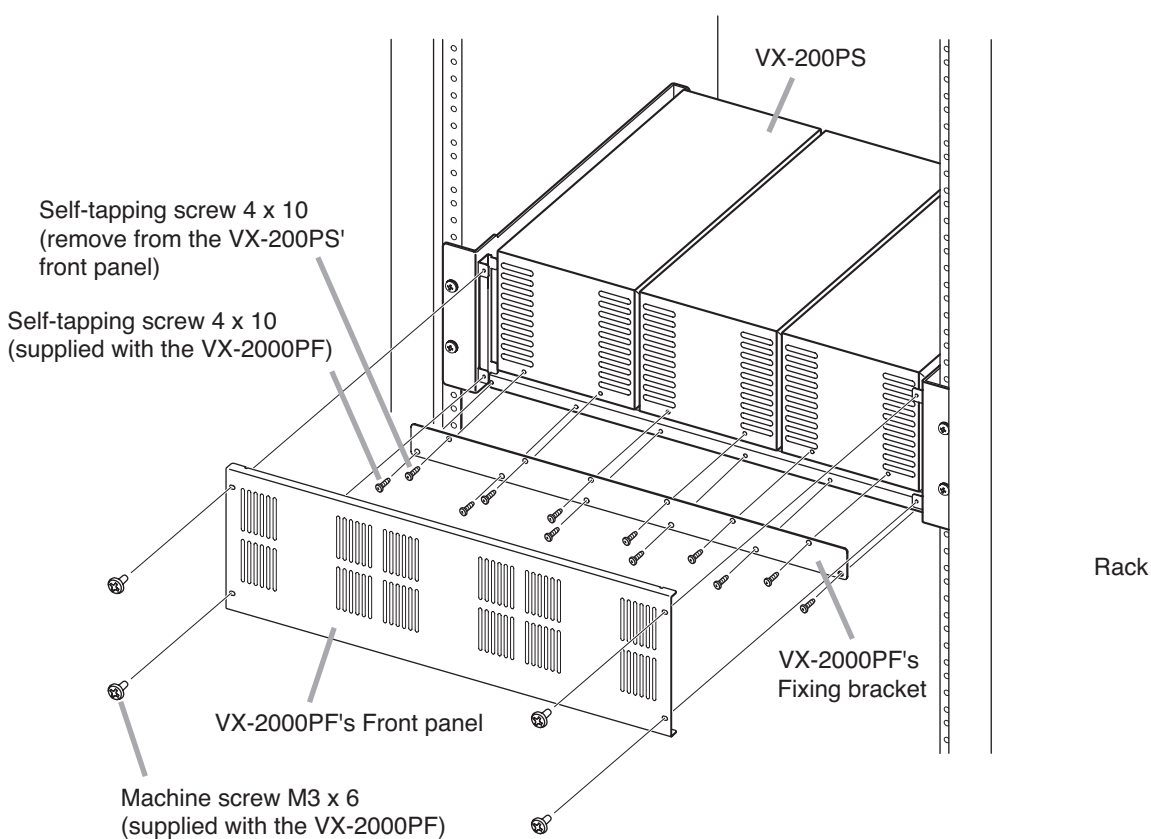

### 3.3. Battery Installation

## WARNING

- Take special care to prevent the battery from being shorted by misconnection of the battery cable. If the short occurs, the unit may fail. Follow the instructions in this section for safe and secure connection.
- Be sure to switch off the system power before battery connection. For the procedure, refer to p. 28 "SWITCHING OFF SYSTEM POWER."
- After completing the battery connection, be sure to attach a terminal cover onto each battery terminal to prevent shorts between positive and negative terminals.

#### [Cable end treatment]

To secure the connection between the battery terminal and cable, be sure to use the cable of specified diameter and treat its end as follows.

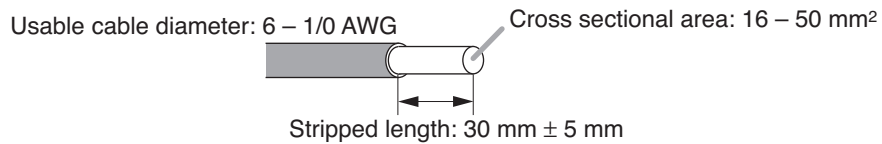

#### [Cautions on cable connection to the battery terminal]

- Before connecting the battery cable to the battery terminal, be sure to fully open the cable clamp by turning the terminal screw counterclockwise.

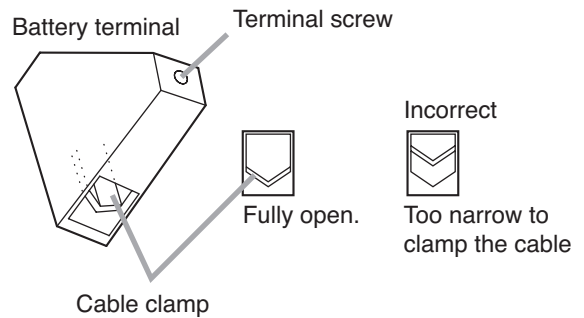

- Insert the battery cable into the correct position in the battery terminal referring to the terminal's cross sectional diagrams below.

#### Correct position of the cable insertion

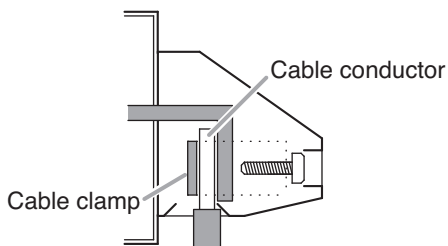

#### Incorrect position of the cable insertion

Wrong insertion position of the cable or a forked cable insertion causes poor contact or insufficient connection tightness, making the cable come off to possibly cause short-circuit accident.

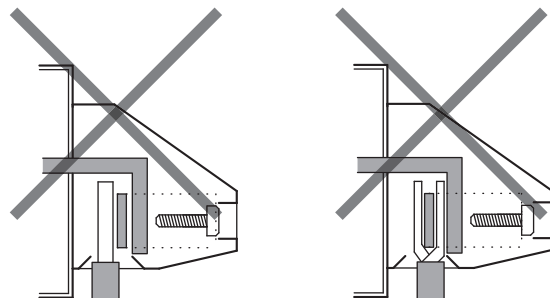

- Strip the cable end long enough (30 mm ± 5 mm) to be fully clamped. Otherwise, its outer jacket prevents the cable conductor from being tightly secured, causing poor contact.

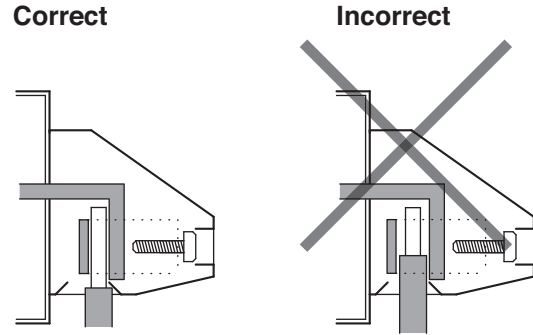

**[Attaching the insulating sheet]**

To prevent the battery cable from being shorted to the rear panel due to misconnection, attach the supplied insulating sheet in place following the procedures below.

- Step 1.** Remove the screw indicated by the arrow.
- Step 2.** Put the supplied insulating sheet over the battery terminals, and fix it with the removed screw.

**Note**  
Attach the supplied Attention label (German) onto the current English label as required.

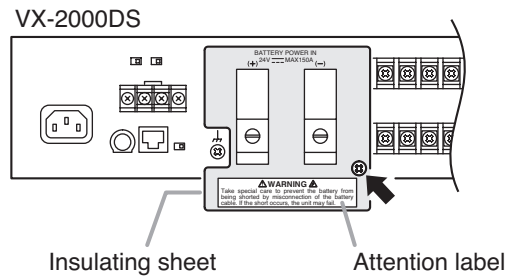

**[Connecting the Battery]**

CAUTION

Note correct polarity (positive and negative orientation) when connecting the power supply cord. Reversed polarity connections will cause damage to the system.

- Step 1.** Allow more than 10 seconds to elapse after removing the power cord from the VX-2000DS' rear-mounted AC inlet.
- Step 2.** Insert the positive battery cable into the VX-2000DS' rear-mounted BATTERY POWER IN positive terminal from the bottom side of connector, then tighten the terminal screw with a flat screwdriver.
- Note**  
Never connect the negative cable first to avoid battery short-circuit that occurs if the positive cable should contact the unit chassis or equipment rack.
- Step 3.** Connect the negative battery cable to the negative terminal in the same manner as **Step 2**.

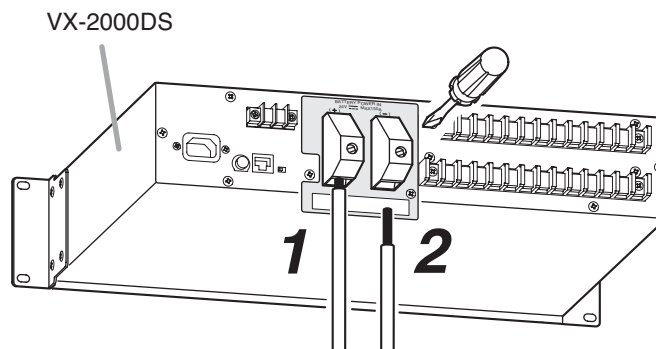

## [Disconnecting the Battery]

**Step 1.** Confirm that battery power is not in use by means of the VX-2000DS' front-mounted BATTERY POWER LED, which is unlit in this case.

**Step 2.** Loosen the VX-2000DS' BATTERY POWER IN negative terminal screw, then pull out the negative battery cable.

### **Notes**

- Never remove the positive cable first to avoid battery short-circuit that occurs if the positive cable should contact the unit chassis or equipment rack.
- Insulate the exposed end of the removed cable with insulating tape to avoid shorting to the other cable.

**Step 3.** Remove the positive battery cable from the positive terminal in the same manner as **Step 2**.

### **Note**

Insulate the exposed end of removed cable with insulating tape to avoid shorting to the other cable.

**[Installing a thermistor]**

The thermistor located on the VX-2000DS' rear panel is designed to compensate for temperature changes when charging the battery. It should be left hanging in the space around the battery.

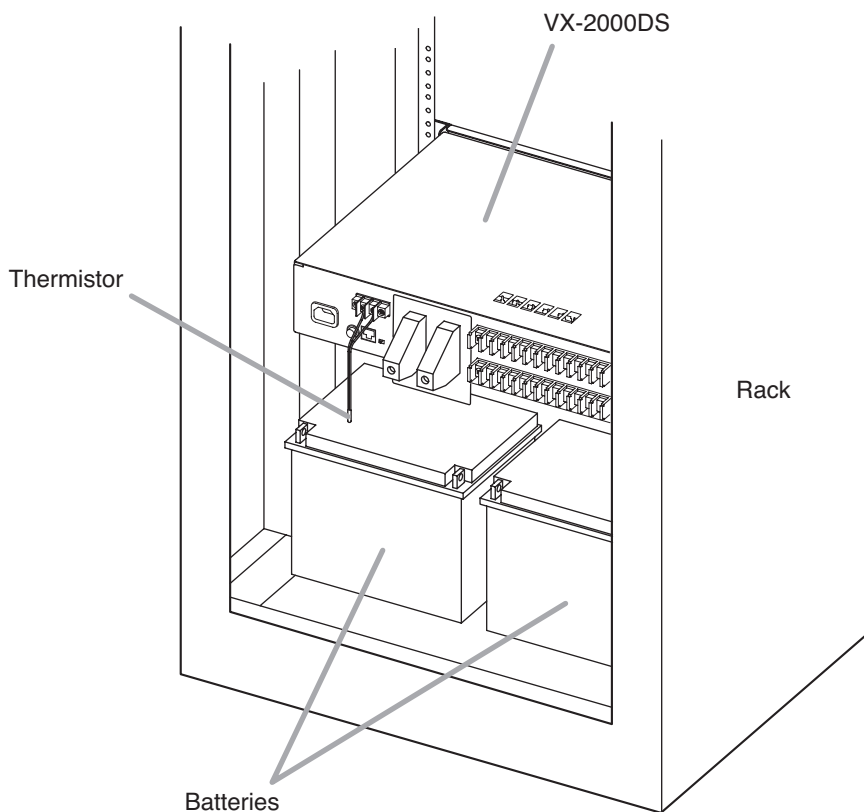

**[Fixing the battery] (ER/UK version only)**

To comply with EN 54-4, fix the battery at the bottom plate surface of the rack as shown below. Attach hook fasteners to the bottom surface of each battery, and loop fasteners to the bottom plate surface of the rack.

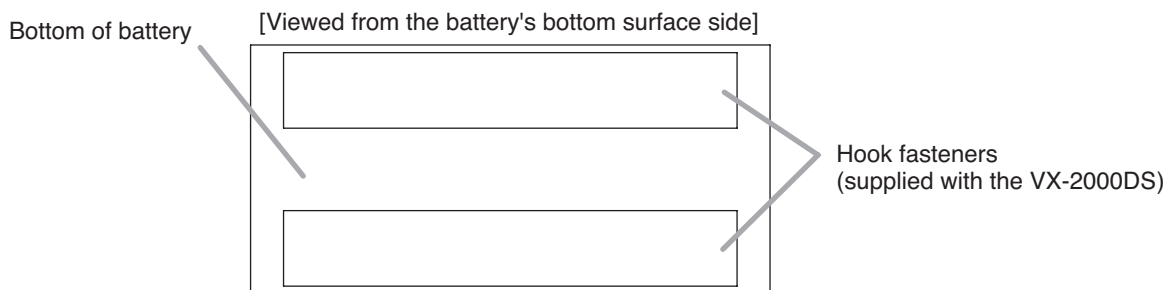

When replacing the batteries, 4 each of fastener hooks and loops listed below are also required. Consult your nearest TOA dealer to buy them.

Part code	Part name
135-01-075-2	VX-2000DS FASTENER HOOK (A)
135-01-076-3	VX-2000DS FASTENER LOOP (B)

### 3.4. Affixing Declaration of Compliance (EN 54-4 Standard, ER/UK versin only)

To declare that the VX-2000DS, VX-2000PF, and VX-200PS comply with EN 54-4, affix the sticker supplied with the VX-2000DS visible to the front panel of the equipment (e.g. at the upper right side as shown below).

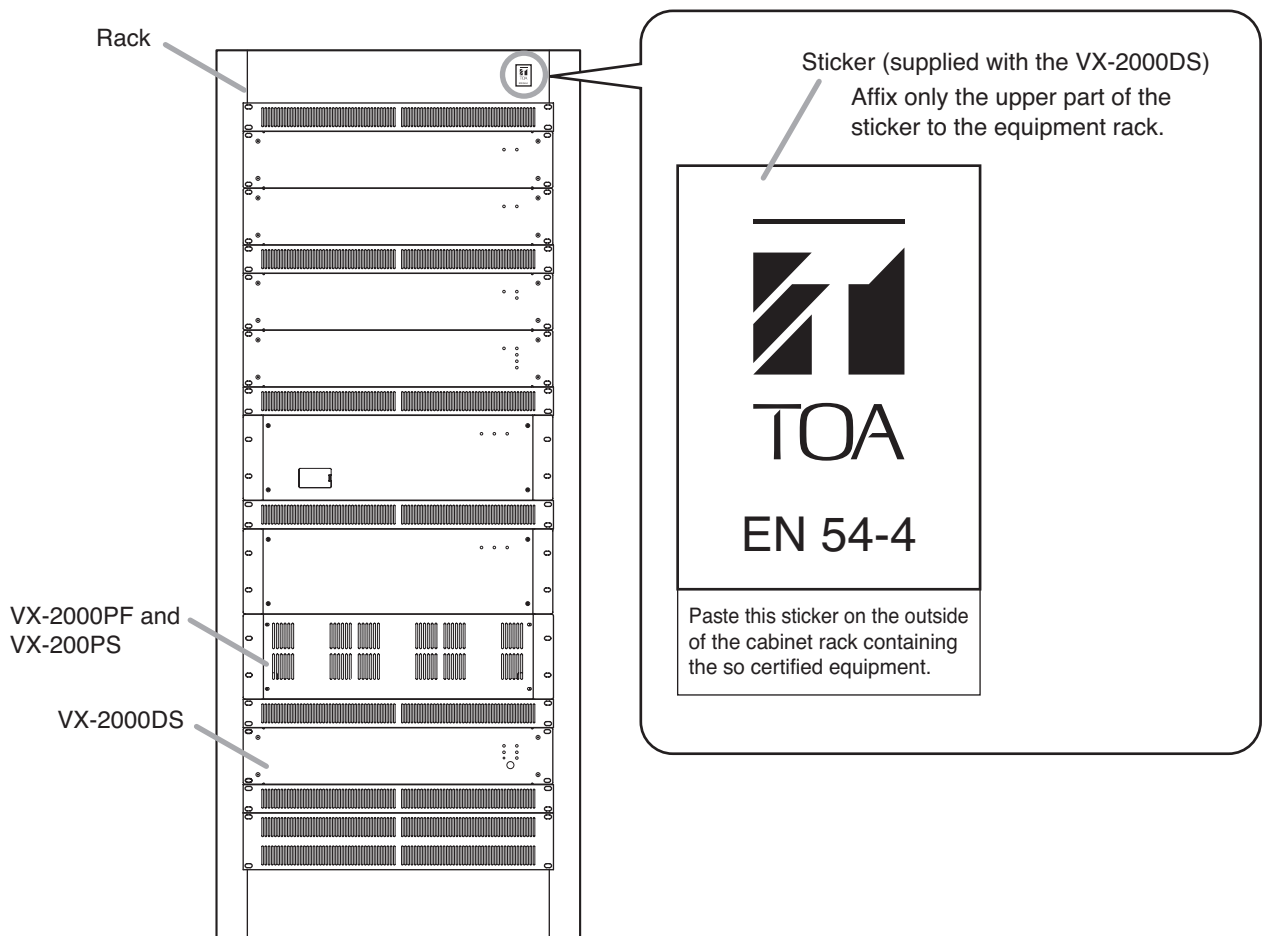

## 4. CONNECTIONS WHEN USING WITH THE VX-2000 SYSTEM

### 4.1. Connections between VX-2000DS and VX-200PS

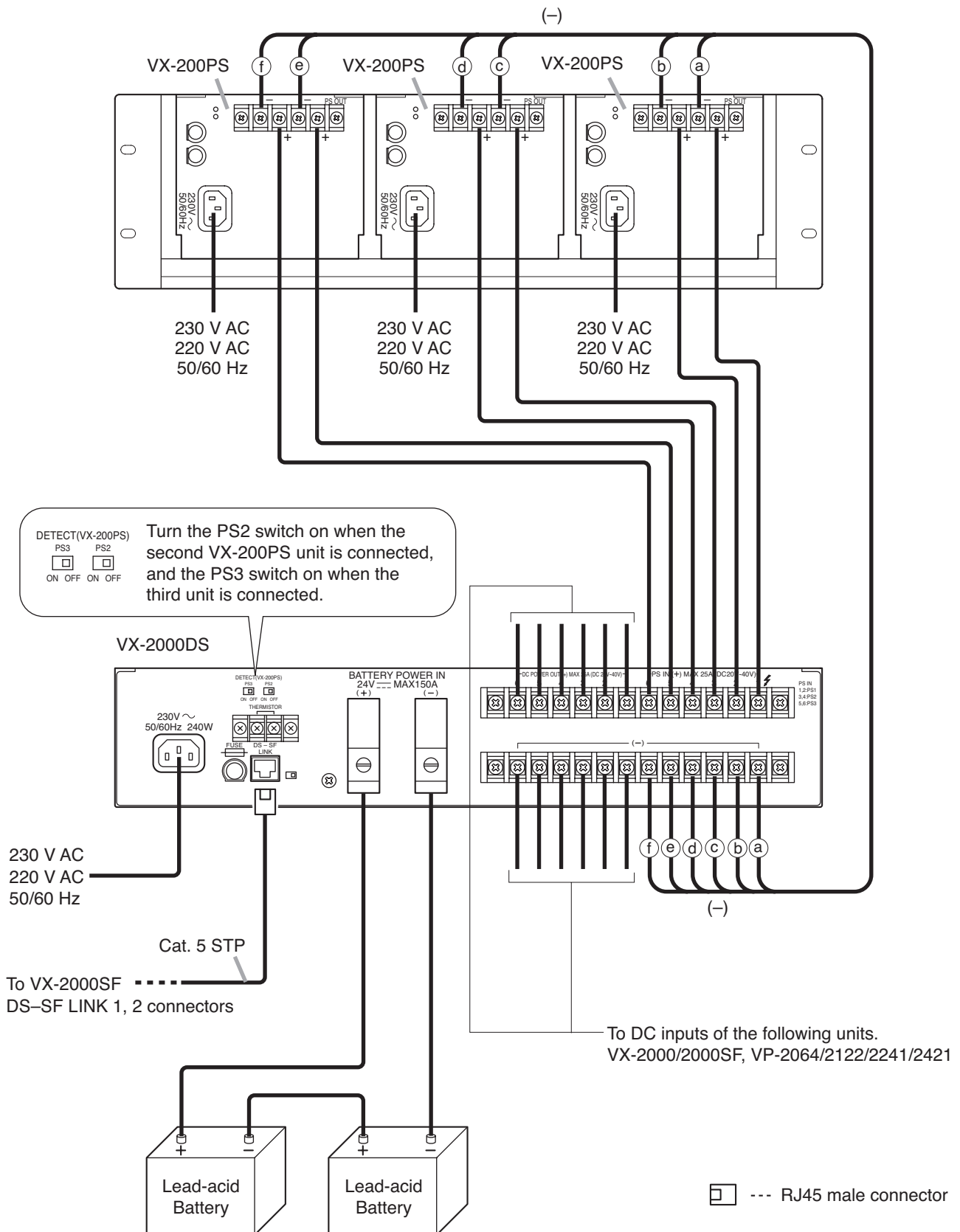

#### Caution

The charging current from VX-2000DS is 5 A maximum.  
Applicable Batteries: Panasonic LC-X1265PG/APG



## 4.2. Connecting the VX-2000DS to VX-2000 System

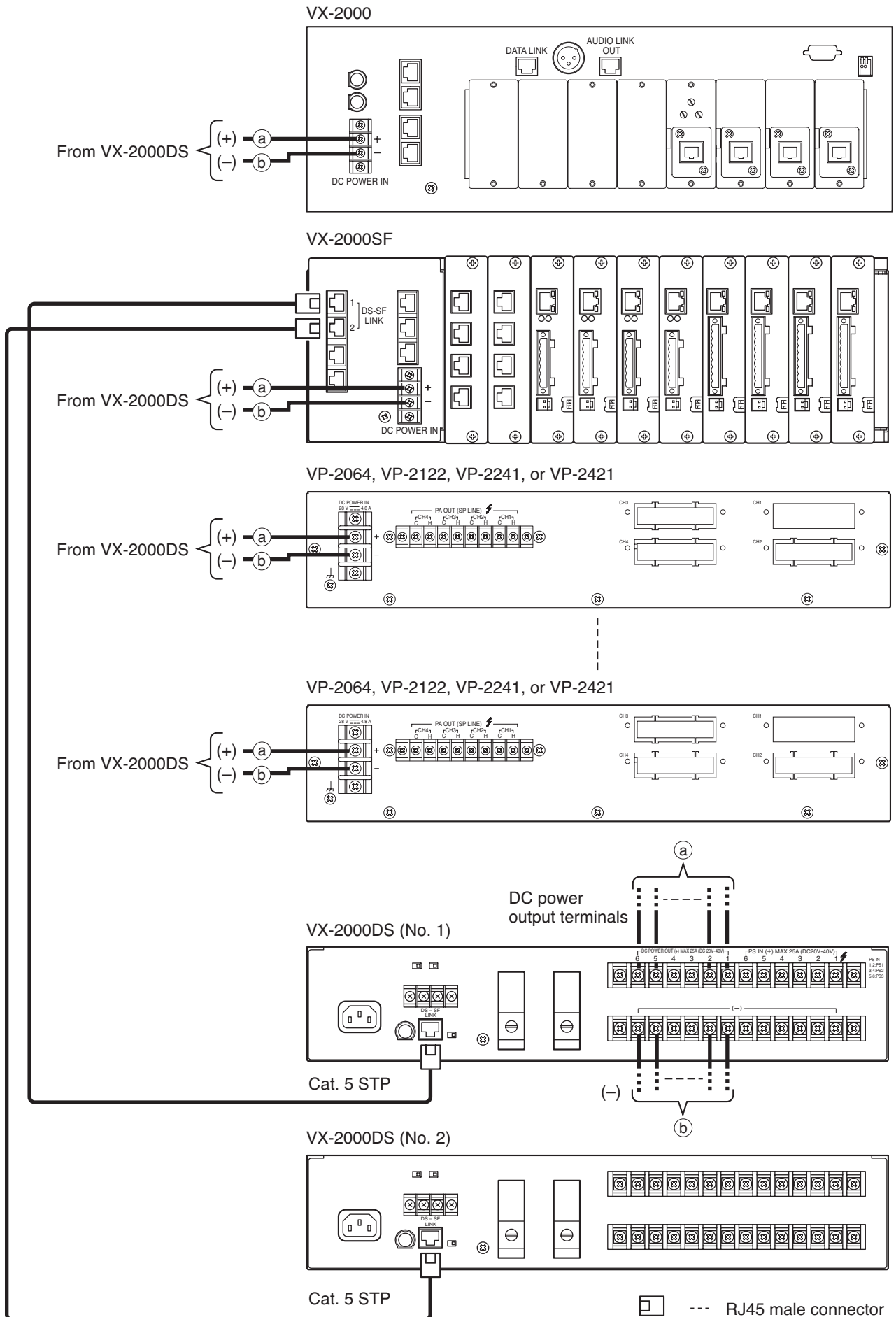

# 5. CONNECTIONS WHEN USING WITH THE SX-2000 SYSTEM

## 5.1. Connections between VX-2000DS and VX-200PS

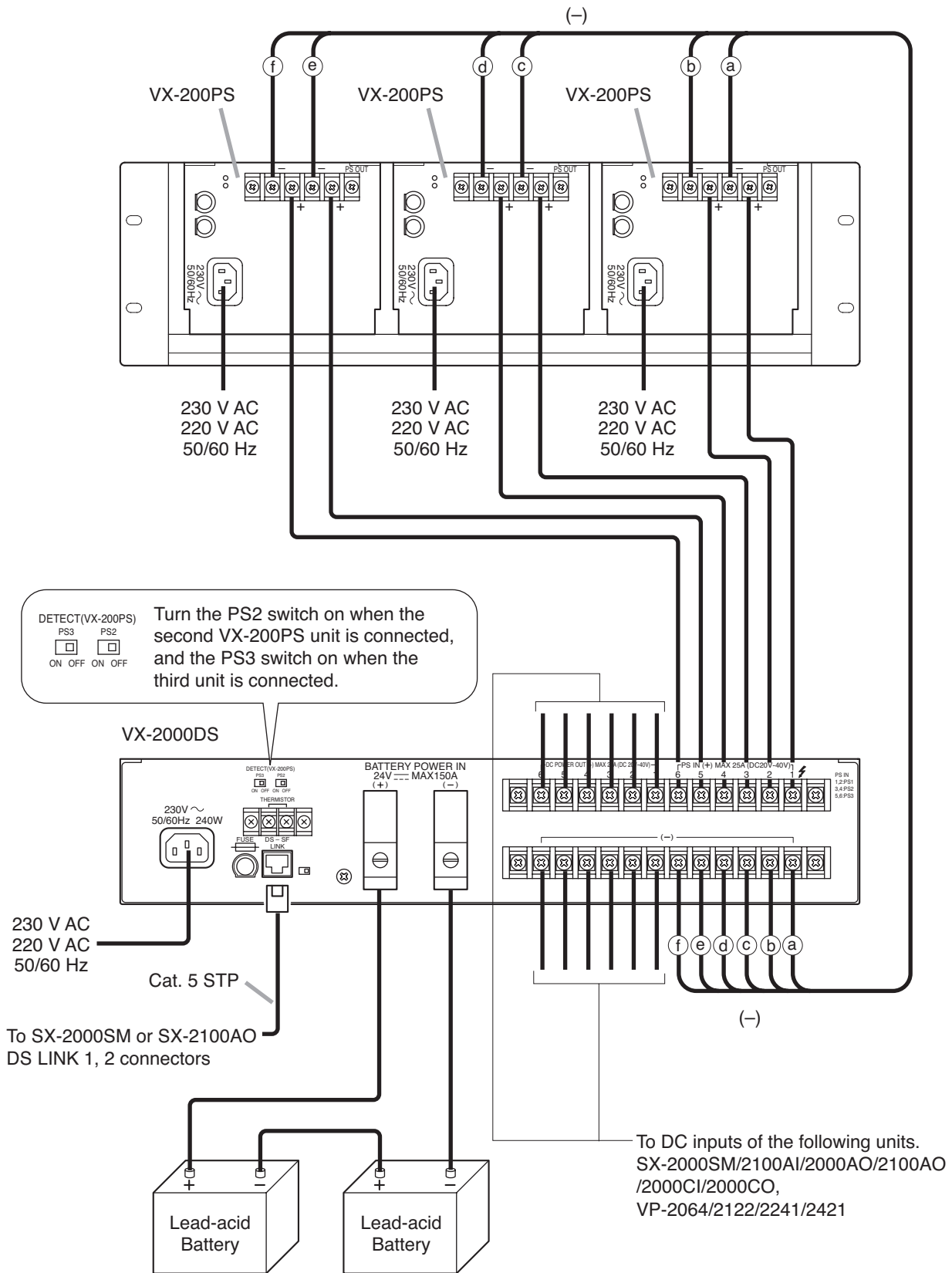

**Caution**

The charging current from VX-2000DS is 5 A maximum.  
Applicable Batteries: Panasonic LC-X1265PG/APG

--- RJ45 male connector

## 5.2. Connecting the VX-2000DS to SX-2000 System

[When using a redundant power system\*]

In this connection example, 2 power supply units are used. Even if one of the 2 units fails or its power supply line is broken, power is still supplied from the other unit, preventing the system from going down.

\* A method of connecting separate power sources to each power input or connecting the commercial power supply and backup power supply separately to each power input to prevent the system from going down when a cable is broken or power fails.

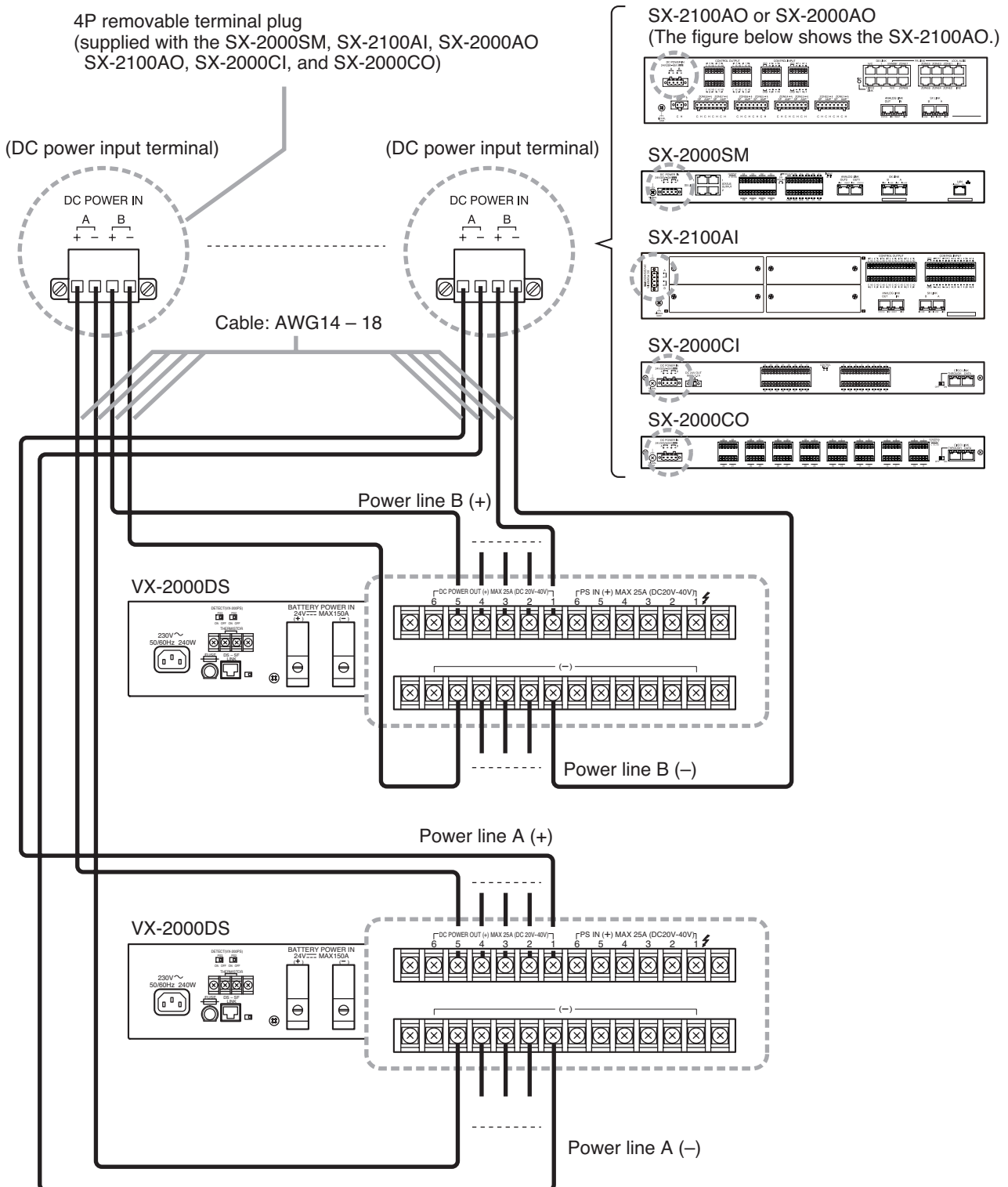

**[When not using a redundant power system]**

Required power is supplied to the system from a single power supply unit. Connect the [+] terminal of Input A to the [+] terminal of Input B, and the [-] terminal of Input A to the [-] terminal of Input B.

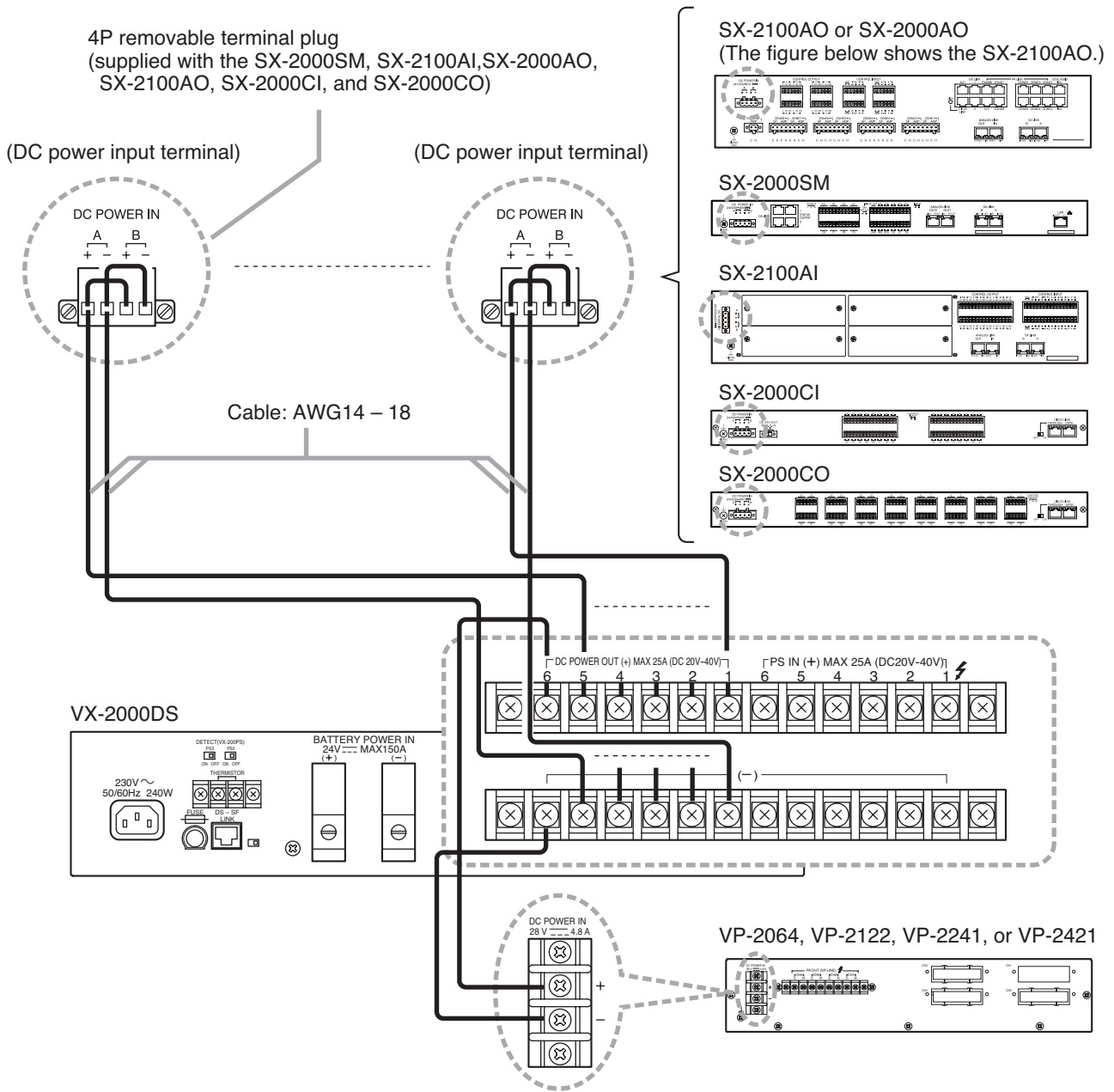

**Note**

When connecting 2 power cables to a single terminal of the removable terminal plug, use a ferrule terminal with an insulation sleeve to crimp the cables because such cable conductors could become loose.

Recommended "Phoenix Contact" ferrule terminals for power supply cables

	Model Number	a	a <sub>1</sub>	a <sub>2</sub>	b	l <sub>1</sub>	l <sub>2</sub>
①	AI 1,5-8 BK	3.4 mm	—	—	1.8 mm	14 mm	8 mm
②	AI-TWIN 2 x 1,5-8 BK	—	6.6 mm	3.6 mm	2.3 mm	16 mm	8 mm

Crimping tool: CRIMPFOX UD6-4 (made by Phoenix Contact)

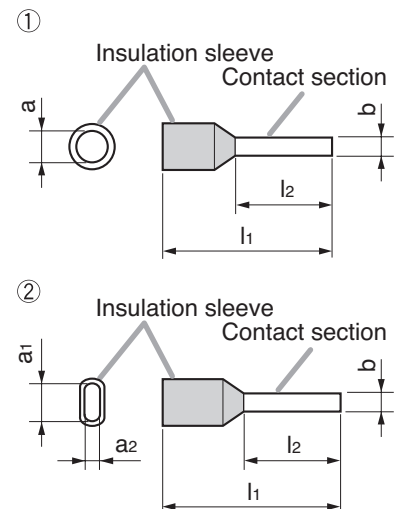

### 5.3. DS Link Terminal Connections

Connect the DS-SF LINK terminal of the VX-2000DS to the DS Link terminal of the SX-2100AO or SX-2100AO. The figure below shows a connection example when the VX-2000DS units are connected to the SX-2100AO. This connection also applies to the SX-2000SM.

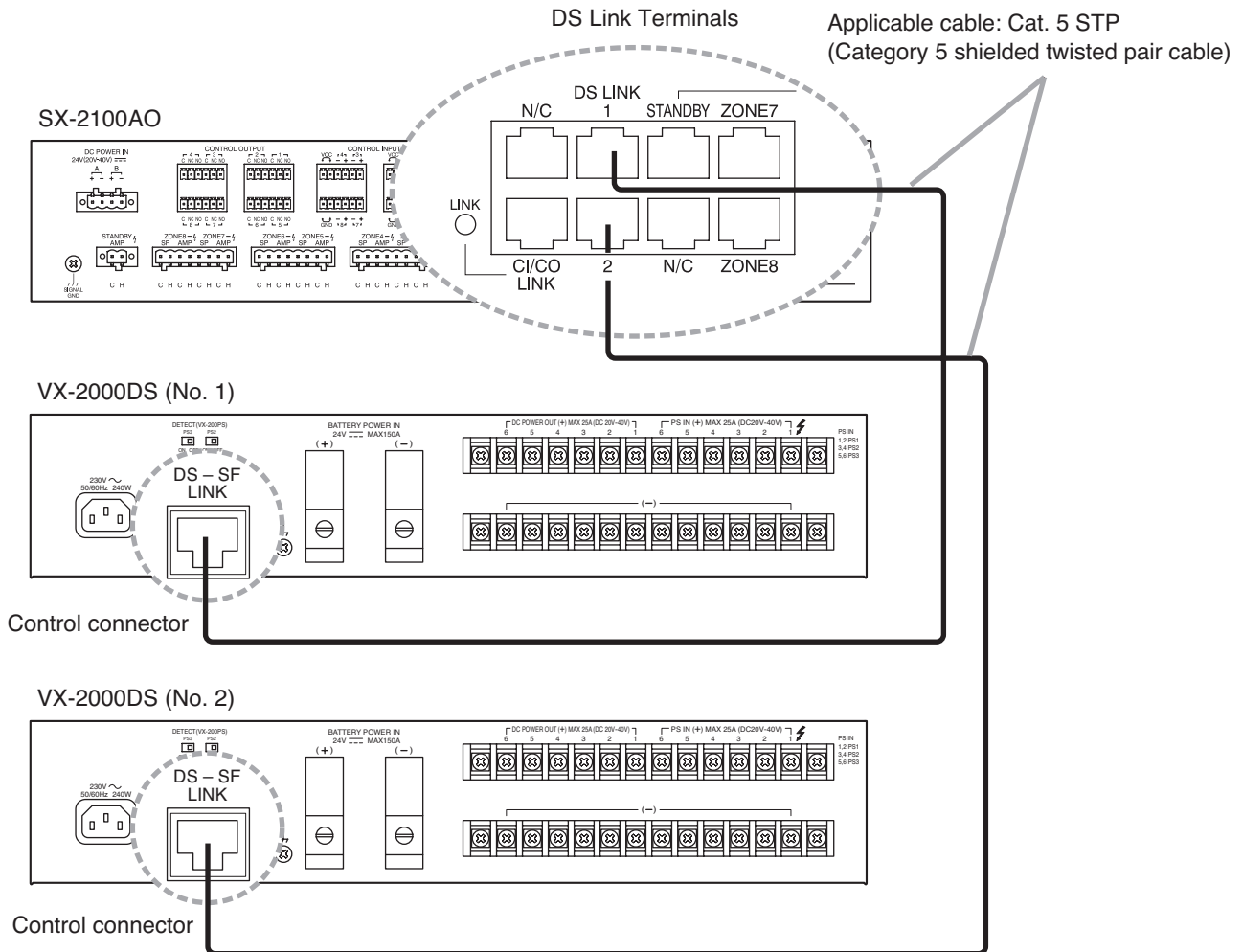

## 6. CONNECTIONS WHEN USING WITH THE VM-3000 SYSTEM

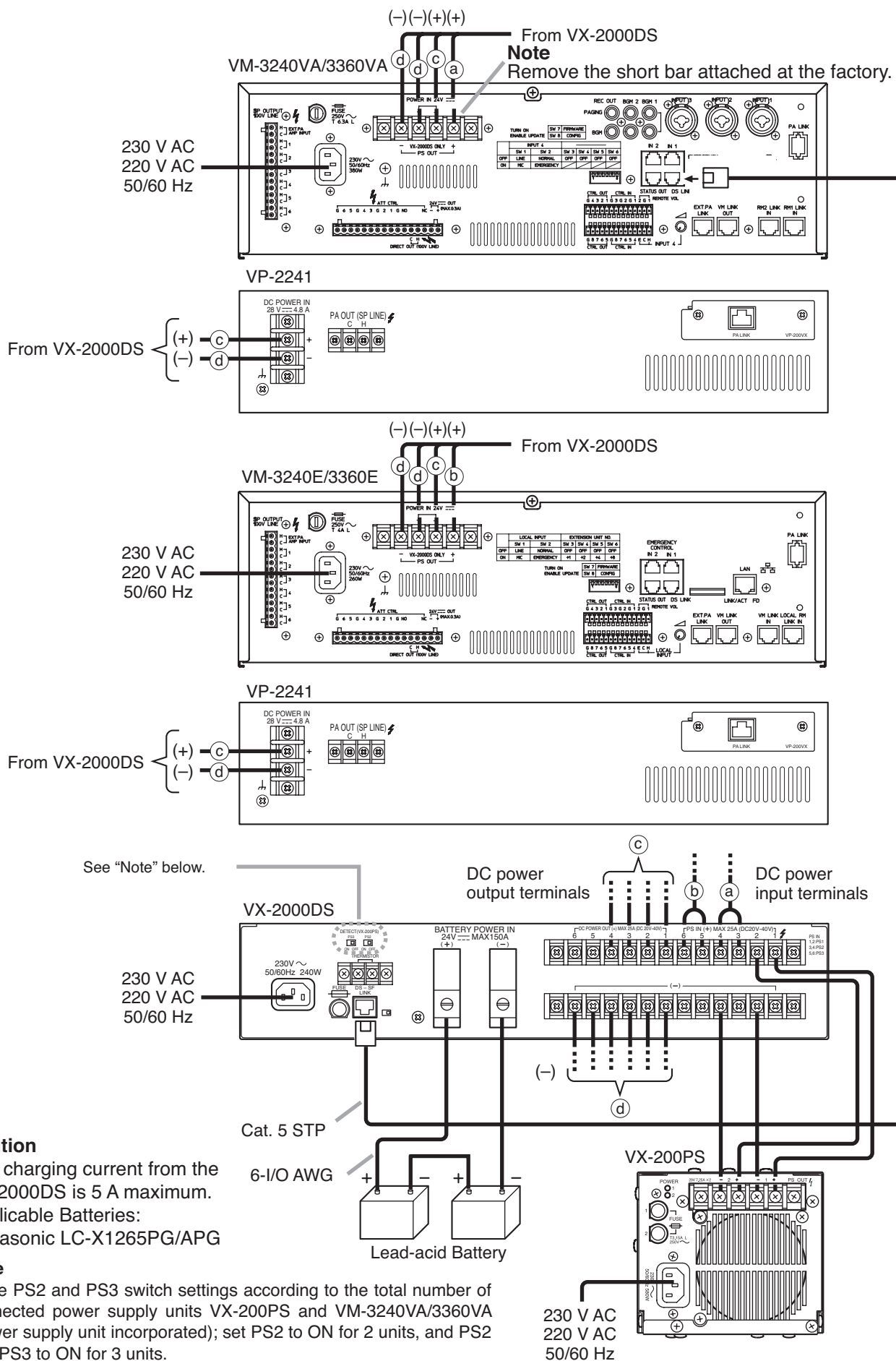

### Caution

The charging current from the VX-2000DS is 5 A maximum.  
Applicable Batteries:  
Panasonic LC-X1265PG/APG

### Note

Make PS2 and PS3 switch settings according to the total number of connected power supply units VX-200PS and VM-3240VA/3360VA (power supply unit incorporated); set PS2 to ON for 2 units, and PS2 and PS3 to ON for 3 units.

Note that these power supply units should be connected to the PS IN (+) terminals 1 and 2 for the 1st unit, 3 and 4 for the 2nd unit, and 5 and 6 for the 3rd unit.

**[Required number of VX-200PS and VX-2000DS units]**

The required number of the VX-2000DS Emergency Power Supply units and VX-200PS Power Supply Units are determined depending on the application of the system configured with the VM-3240VA, VM-3360VA, VM-3240E, and VM-3360E (hereinafter called "VM amplifier"), and/or the VP-2241 and VP-2421 (hereinafter called "VP amplifier").

**• Required number in a 1-channel broadcasting system**

**System including VM amplifiers only**

One VX-2000DS is required every 3 VM amplifiers. The VX-200PS is not needed in this system.

Number of VM amplifiers	1	2	3	4	5	6	7	8	9	10
Number of VX-2000DS units	1			2			3			4

Below is an example showing that one VX-2000DS is used in a system including 3 VM amplifiers.

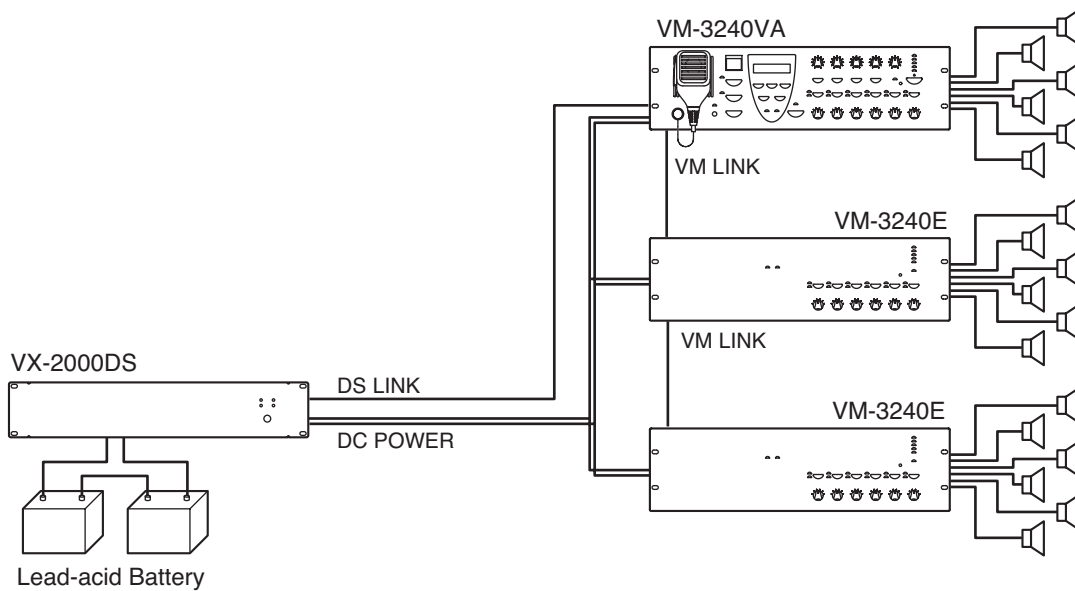

### System including one VP amplifier connected as a standby amplifier

One VX-2000DS is required every 3 VM amplifiers.

Number of VM amplifiers	1	2	3	4	5	6	7	8	9	10	
Number of VX-2000DS units	1					2		3			4
Number of VX-200PS units	0			1							

Below is an example showing that 2 VX-2000DSs and 1 VX-200PS are used in a system including 4 VM amplifiers.

**Note**

Connect the VX-200PS to the VX-2000DS to which the VP amplifier is connected.

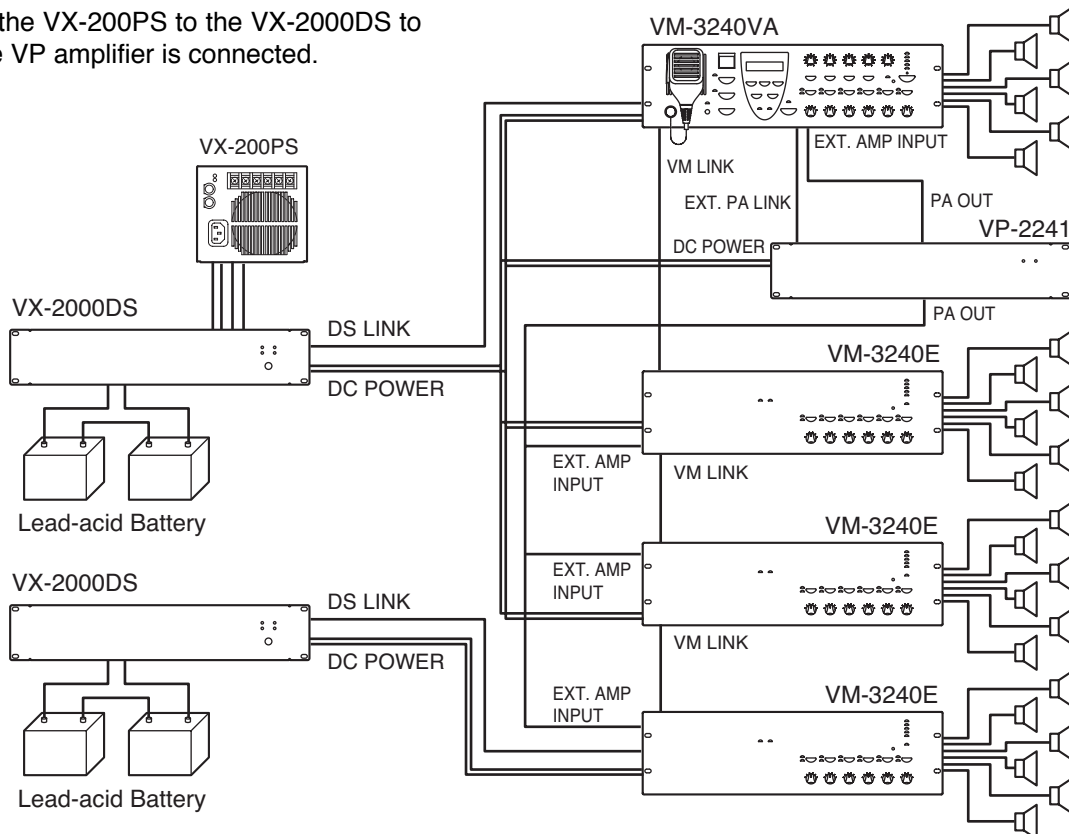



• **Required number of VX-2000DS and VX-200PS units in a BGM/Paging system**

One each of the VX-2000DS and VX-200PS is required every 2 VM amplifiers.

Number of VM amplifiers	1	2	3	4	5	6	7	8	9	10
Number of VX-2000DS units	1	2	3	4	5	6	7	8	9	10
Number of VX-200PS units	1	2	3	4	5	6	7	8	9	10

Below is an example showing that 2 each of VX-2000DSs and VX-200PSs are used in a system including 3 VM amplifiers.

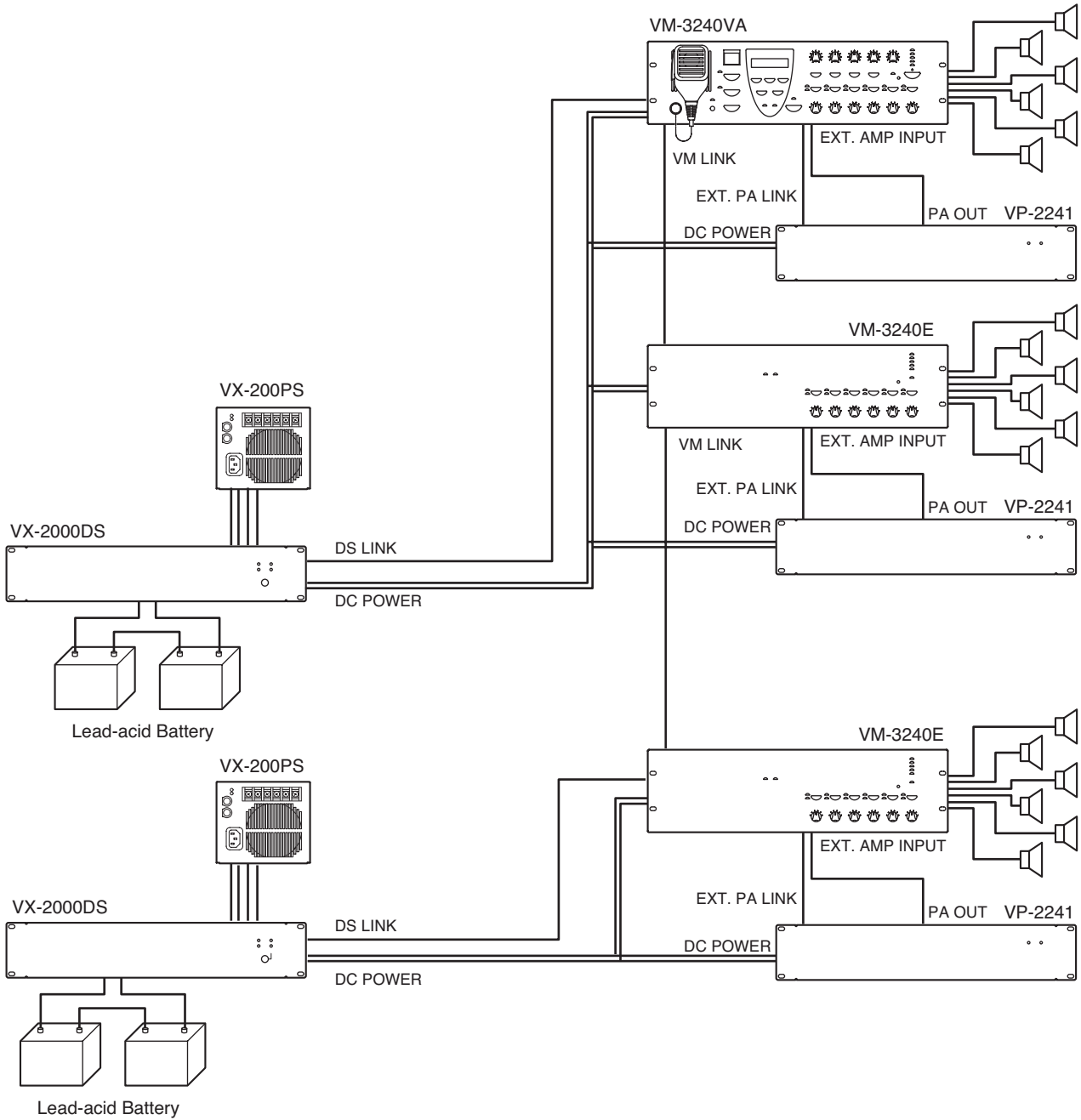

**Notes**



- A pair of the VM amplifier and VP amplifier should be connected to the same VX-2000DS.
- One VX-200PS should be connected to each VX-2000DS.

# 7. CABLE USAGE TABLE

## [VX-2000DS]

Terminal to Connect		Cable Type			Equipment to be Connected to		
Terminal Name	Equipment Receptacle	Plug	Cable Type	Plug	Equipment	Terminal Name	Equipment Receptacle
AC IN	3P inlet	—	Supplied cable	—	230 V AC, 50/60 Hz 220 V AC, 50/60 Hz	—	—
DS-SF LINK	RJ45 (female)	RJ45 (male)	Cat. 5 STP	RJ45 (male)	VX-2000SF	DS-SF LINK	RJ45 (female)
BATTERY POWER IN	Screw terminal	Unprocessed cable end	6-1/0AWG	Unprocessed cable end	Lead-acid battery	Electrode (+, -)	—
DC POWER OUT	Screw terminal	Round terminal	14 – 18 AWG	Round terminal	VX-2000 VX-2000SF VP-2064/2122/2241 /2421	DC POWER IN	2P screw terminal
			—	DC plug (Outer diameter: F5.5 mm Inner diameter: F2.1 mm Length: 9.5 mm)	RM-200X RM-200SA RM-200M	DC IN	DC jack
			12 – 24 AWG	Unprocessed cable end	RM-200XF	LINK (DC Power In +)	9P plug-in screw terminal
			14 – 18 AWG	Round terminal	SX-2000SM SX-2100AI SX-2000AO SX-2100AO SX-2000CI SX-2000CO	DC POWER IN	4P removable terminal plug
			8 – 10 AWG	Round terminal	VM-3240VA VM-3360VA VM-3240E VM-3360E	DC POWER IN	2P screw terminal
			12 – 24 AWG	Round terminal	RM-200SF RM-300MF	DC IN 24 V	Screw terminal
PS IN	Screw terminal	Round terminal	10 – 14 AWG (line resistance within 10 mΩ)	Round terminal	VX-200PS	PS OUT	Screw terminal

### • VX-2000DS' DS-SF LINK Connections

Connector Name	RJ45 Pin No.	Colour	Pair	Assignment	Direction/Level
DS-SF Link	1	Orange/white		Connection Check	Output/0 – 3.3 V
	2	Orange		Battery Failure	
	3	Green/white		Charging Circuitry Failure	
	4	Blue		DC Off	
	5	Blue/white		AC Off	
	6	Green		3.3 V DC Input	Input (DC)/3.3 V
	7	Brown/white		NC	—
	8	Brown	Battery Check Activation	Input/0 – 3.3 V	
	Shield	Shield	Chassis GND	—	

## [VX-200PS]

Terminal to Connect		Cable Type			Equipment to be Connected to		
Terminal Name	Equipment Receptacle	Plug	Cable Type	Plug	Equipment	Terminal Name	Equipment Receptacle
AC IN	3P inlet	—	Supplied cable	—	230 V AC, 50/60 Hz 220 V AC, 50/60 Hz	—	—
PS OUT	Screw terminal	Round terminal	10 – 14 AWG (line resistance within 10 mΩ)	Round terminal	VX-2000DS	PS IN	Screw terminal

# 8. USING THE VX-2000DS EXCLUSIVELY AS A BACKUP POWER SUPPLY

The VX-2000DS can be used with the VM-2000 series system or other systems as a backup power supply unit which supplies battery power to the system when AC mains fail.

To permit the VX-2000DS operation in this system configuration, shift the VX-2000DS' rear-mounted Setting switch to the AC position (factory-preset to the DC position).

## [Setting and connection example for the VX-2000 system]

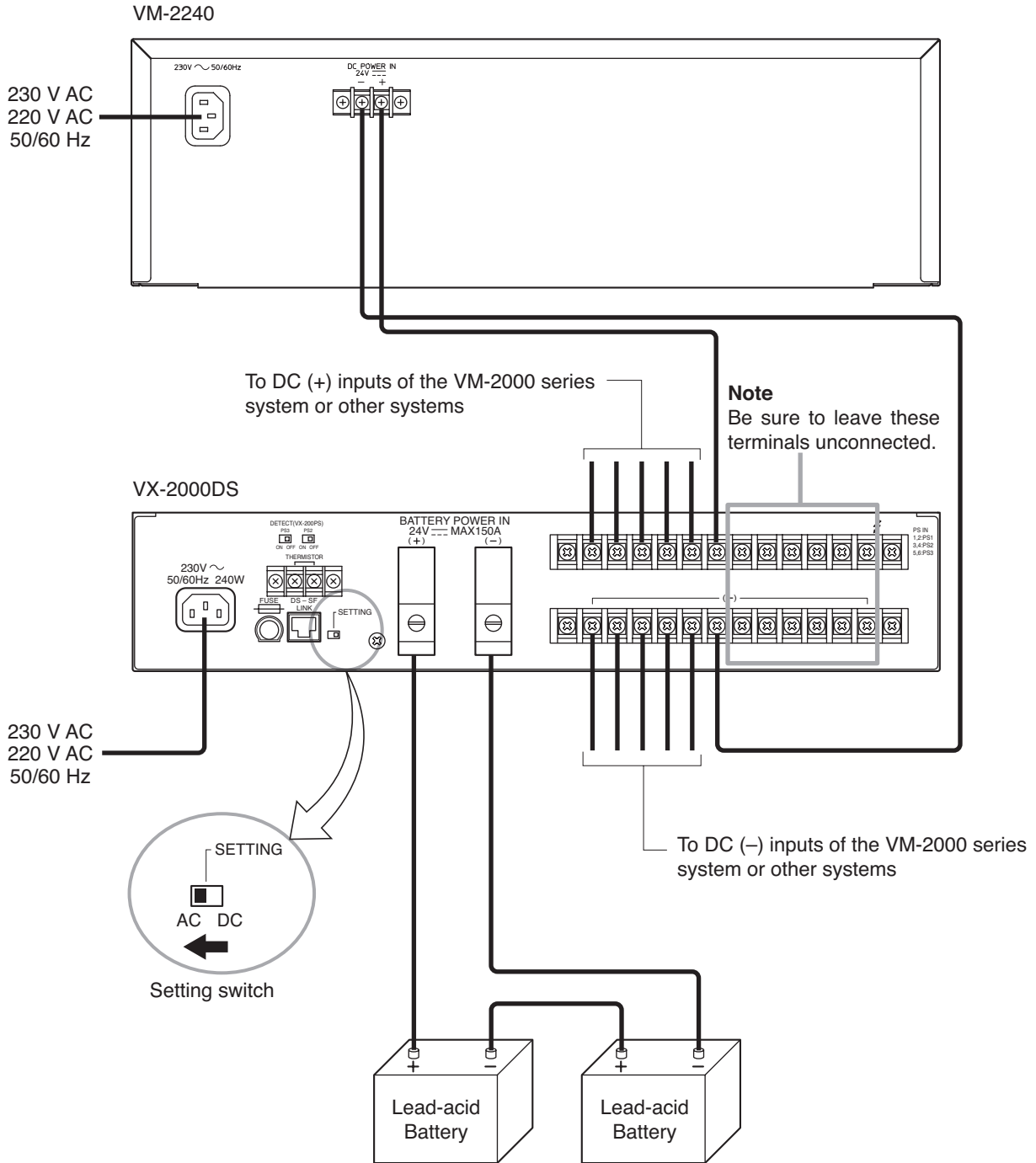

**Caution**

The charging current from VX-2000DS is 5 A maximum.  
Applicable Batteries: Panasonic LC-X1265PG/APG

**Note:** Internal setting change is required. Leave this work to service personnel. Contact your TOA dealer.

## 9. SWITCHING OFF SYSTEM POWER (DC)

When the system power (DC) needs to be switched off in such cases as maintenance or unit configuration change, shift the Setting switch on the VX-2000DS to the "AC" position following the procedure below.

### [To switch off the system power]

**Step 1.** Terminate all current broadcasts to stop system operation.

**Step 2.** Shift the Setting switch on the VX-2000DS rear panel to the "AC" position.

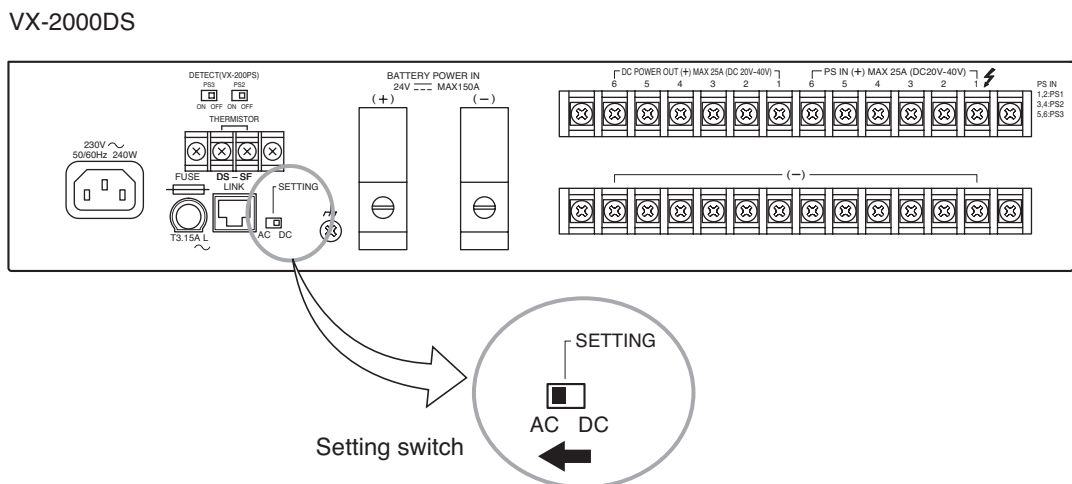

**Step 3.** Stop the AC power supply to the VX-200PS.

This permits the system power to be switched off without switching over to battery operation.

#### **Note**

Never stop the AC power supply to the VX-2000DS as doing so causes the system power source to be maintained by the battery.

### [To restore the power supply to the system]

**Step 1.** Restore the AC power supply to the VX-200PS.

The DC power is supplied from the VX-200PS to the VX-2000DS.

**Step 2.** Shift the Setting switch on the VX-2000DS rear panel back to the "DC" position.

**Step 3.** Operate the system normally.

# 10. BLOCK DIAGRAM

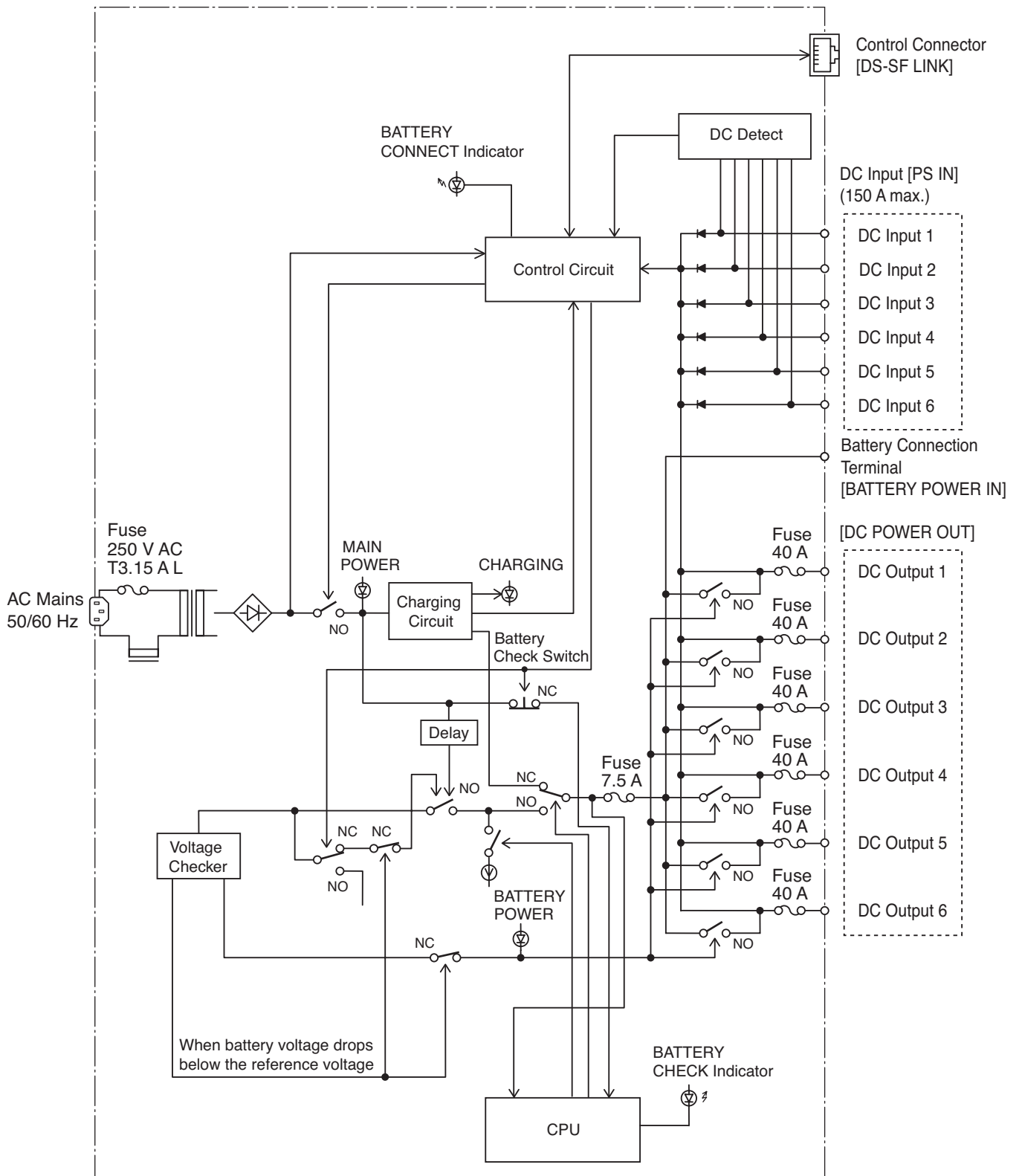

# 11. SPECIFICATIONS

## 11.1. VX-2000DS Emergency Power Supply

Power Source	230 V AC (ER/UK), 220 – 230 V AC (SA), 50/60 Hz
Power Consumption	240 W max.
Applicable Battery	Panasonic LC-X1265PG/APG (65 Ah)
Charging Method	Trickle charging
Charging Current	5 A max.
Charging Output Voltage	27.3 V $\pm$ 0.3 V (at 25°C) Temperature correction coefficient: –40 mV/°C
Power Supply Input	6, M4 screw terminal, distance between barriers: 11 mm
DC Power Output	6 (25 A max. each), M4 screw terminal, distance between barriers: 11 mm
Control Connector	RJ45 female connector for connecting the VX-2000SF Surveillance Frame Twisted-pair straight cable (TIA/EIA-568A standard) Type of control signal: Battery check, AC power status, DC power status, charging circuit failure, and battery failure
Battery Connection	1 pair of positive and negative terminals Applicable cable diameter: AWG 6 – AWG1/0 (Line resistance within 4 m $\Omega$ /total)
Operating Temperature	0 to +40°C
Finish	Panel: Surface-treated steel plate, black (30% gloss), paint
Dimensions	482 (w) x 88.4 (h) x 377.6 (d) mm
Weight	10.5 kg

Fuse ratings	Blade fuse (40 A), Blade fuse (7.5 A), Fuse (7.5 A)
Maximum output current draw from the battery	43.5 A
Maximum internal resistance of the battery and its associated circuitry, Ri max	50 m $\Omega$
Rated maximum continuous output current, I max a	43.5 A
Rated maximum short duration output current, I max b	43.5 A
Rated minimum output current, I min	0 A
Recommended cable parameter for DS-SF Link	Twisted-pair straight cable (TIA/EIA-568A standard)

**Note:** The design and specifications are subject to change without notice for improvement.

• **Accessories**

- Rack mounting screw (5 x 20) ..... 4
- Fiber washer ..... 4
- Blade fuse (40 A) ..... 3
- Fuse (T3.15 A L) ..... 1
- Insulating sheet ..... 1
- Attention label (German) ..... 1
- Power cable (2 m) ..... 1

(ER/UK version only)

- Fastener hook ..... 4
- Fastener loop ..... 4
- Sticker (Declaration of compliance) ..... 1

### 11.2. VX-200PS Power Supply Unit

Power Source	230 V AC (ER/UK), 220 – 230 V AC (SA), 50/60 Hz
Power Consumption	580 W
DC Power Output	Rated output: 210 W (29 V, 7.25 A) x 2 Peak output: 400 W x 2 M4 screw terminal, distance between barriers: 11 mm Applicable cable diameter: 10 – 14 AWG (line resistance within 10 mΩ)
Ripple Voltage at I <sub>max</sub> B (at VX-2000DS's DC Output)	Max. 4 V
Operating Temperature	0 to +40°C
Applicable Frame	VX-2000PF
Finish	Surface-treated steel plate
Dimensions	135 (w) x 118.2 (h) x 333.8 (d) mm
Weight	13.2 kg

**Note:** The design and specifications are subject to change without notice for improvement.

• **Accessories**

- Fuse (T3.15 A L) ..... 1
- Power cable (2 m) ..... 1

### 11.3. VX-2000PF Power Supply Frame

Finish	Panel: Surface treated steel plate, black (30% gloss), paint
Dimensions	483 (w) x 132.6 (h) x 324.8 (d) mm
Weight	5.5 kg
Product Composition	Side Panel ..... 2, Front panel .....1, Chassis ..... 1, Fixing bracket* ..... 1
Usable Unit	VX-200PS (up to 3)

\* The Fixing bracket is not supplied with the previous VX-2000PF. (Refer to p. 9, "Installation Precautions.")

**Note:** The design and specifications are subject to change without notice for improvement.

• **Accessories**

- Self-tapping screw (4 x 10) ..... 16
- Machine screw M3 x 6 ..... 4
- Rack mounting screw (5 x 12) ..... 4
- Fiber washer ..... 4

**Traceability Information for Europe (EMC directive 2004/108/EC)**

Manufacturer:  
TOA Corporation  
7-2-1, Minatojima Nakamachi, Chuo-ku, Kobe, Hyogo,  
Japan

Authorized representative:  
TOA Electronics Europe GmbH  
Suederstrasse 282, 20537 Hamburg,  
Germany